

WARNING

- This wheel is equipped with a quick release hub to facilitate installation and removal. Failure to properly install this quick release hub (wheel) onto your bicycle may cause the wheel to become detached from the bicycle while you are riding and result in serious bodily injury.
- BEFORE USE, CAREFULLY READ THE QUICK RELEASE SERVICE INSTRUCTIONS IN YOUR OWNER'S MANUAL. IF YOU HAVE ANY QUESTIONS, ASK YOUR DEALER. IMPROPER HUB INSTALLATION CAN RESULT IN SERIOUS BODILY INJURY.

SERVICE INSTRUCTIONS SI-3000F

Quick Release

For proper and safe performance, read and follow these instructions carefully.

CAUTION

Be sure to operate the quick release lever by hand only. Never use any other tool such as a hammer to tighten the quick release lever, as this could cause damage to the lever.

What is a Quick Release?

It is a mechanism that uses a single quick release lever operation on the hub to enable the wheel to be easily installed and removed.

Quick Release function

When the quick release lever is brought to the closed position, the lever nut moves inward. The force of this clamps the wheel to the frame and holds the wheel securely in place.

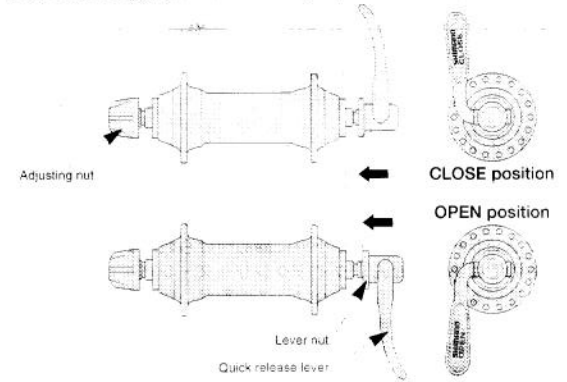

The clamping strength is adjusted by turning the adjusting nut. When the nut is turned in a clockwise direction, the clamping strength increases, and when the nut is turned in a counter-clockwise direction, the clamping strength decreases.

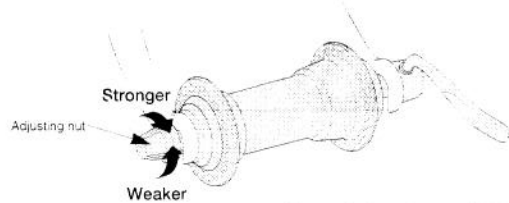

These service instructions are printed on recycled paper and can be recycled again.

SHIMANO
SHIMANO AMERICAN CORPORATION
One Holland Irvine CA 92618 U.S.A. Phone 714 951-5903

SHIMANO EUROPA
Industrieweg 24 NL 8271 CT Nunspeet Holland Phone 31-3472-7222 3177 Omitscho Saka Osaka Japan Phone 0722-29-3141

SHIMANO INC.
Please note: specifications are subject to change for improvement without notice. (English)
© Apr. 1995 by Shimano Inc. XBC SHS Printed in Japan.

Suitable dimensions of the fork end

Be sure to use only fork widths with suitable dimensions.

Front ...
cannot use fork thicknesses less than 4 mm.
(Dura-Ace, 600 Ultegra: not less than 5 mm.)

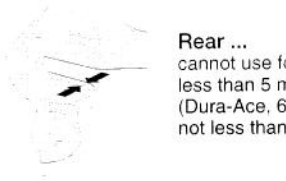

Rear ...
cannot use fork thicknesses less than 5 mm.
(Dura-Ace, 600 Ultegra: not less than 6 mm.)

Operation method

The front axle is explained as an example. The rear axle works in the same way.

How to fasten this quick release hub

1. Move the quick release lever to the OPEN position and set the wheel so it firmly touches the interior of the fork end (See sketch below).

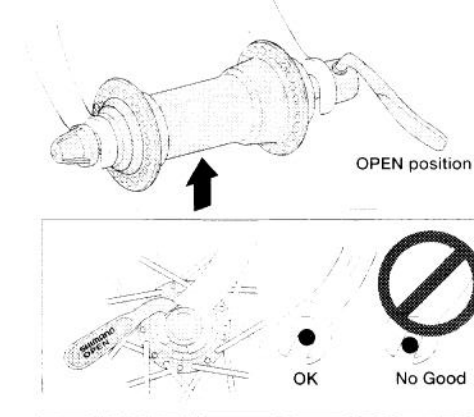

2. Open and close the quick release lever with your right hand while gradually tightening the adjusting nut (located on the opposite side of the hub) with your left hand in the clockwise direction. Continue tightening the nut until you feel resistance with your hand at the point when the lever is parallel to the hub (as indicated by the dotted position in the diagram on the right).



3. Grip the fork with your fingers and use the palm of your hand to close the quick release lever with as much strength as possible. When closed, the quick release lever must be in the "CLOSE" position shown below in the diagram on the right. The side of the lever with the inscription "CLOSE" must be facing away from the wheel, and the lever should be parallel to the fork as shown below in the diagram on the left.

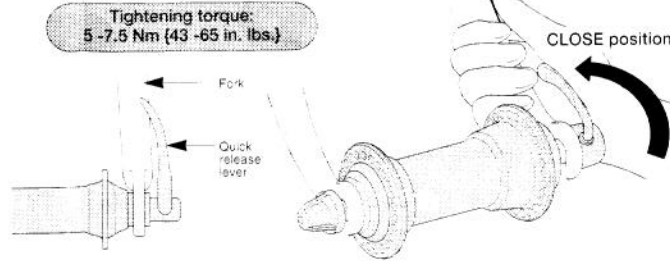

CAUTION

Never fasten a wheel to a frame by rotating the quick release lever as shown in the diagram on the right. Simply rotating the lever in a circular motion will not fasten the wheel to the frame. Detachment of the wheel as a result of improper hub installation can result in serious bodily injury.

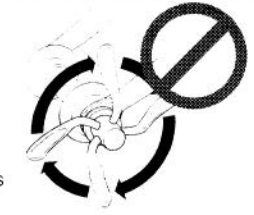

Notes

If the quick release lever can be easily pushed to the CLOSE position, this means the clamping strength is insufficient. Return the quick release lever to the position perpendicular to the bicycle frame and again turn the adjusting nut clockwise to increase the clamping strength. Push the quick release lever back to the CLOSE position.

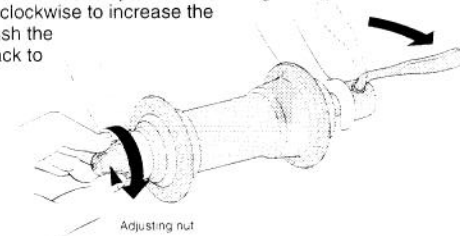

If the clamping strength is adjusted too strong and the quick release lever cannot be pushed to the CLOSE position, turn the adjusting nut in a counter-clockwise direction to reduce the clamping strength. When doing this, do not fully release the adjuster nut. Turn it 1/8 of a revolution, and then try to push the lever to CLOSE.

to set the maximum clamping strength with which you can push the quick release lever to the CLOSE position.

Turn 1/8 revolution at a time

Positioning of the quick release lever

For safety, the quick release lever should be along the bicycle frame when in the CLOSE position.

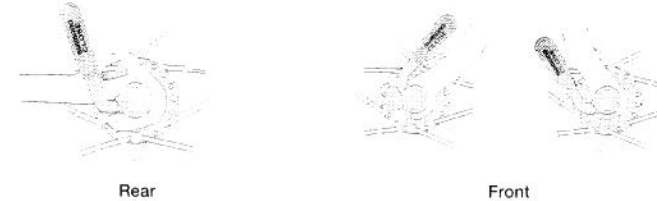

Removing the wheel

Move the quick release lever from the CLOSE position to the OPEN position. This will release the wheel, and it can be removed. There is no need to move the adjusting nut when removing the wheel.

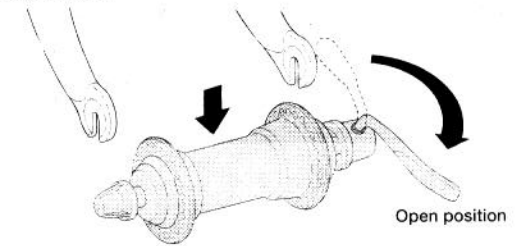

WARNING

THINGS TO CHECK BEFORE RIDING

- Always check your quick release hubs before riding to make sure that the wheels are correctly installed on the bicycle frame. This is especially important after you park your bicycle in a public place.
- Make sure that the quick release levers are pushed fully to the CLOSE position (the side of the lever with the inscription "CLOSE" must be facing away from the wheel). As shown in the diagram on the right, the lever must be lifted, not rotated.

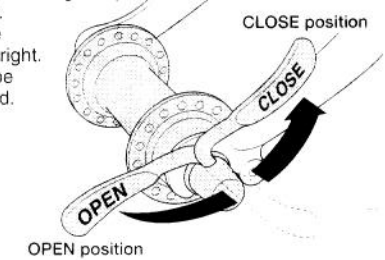

QUICK CHECK

Lift up the bicycle so that the wheel is off the ground, and give the top of the tire a few sharp downward blows as shown in the diagram. The wheel should not be loose or come off. This check does not guarantee that the quick release lever has received adequate tightening torque. If you are uncertain as to whether the quick release is tightened correctly, repeat the installation procedure as explained in "How to fasten this quick release hub" of this service instruction.

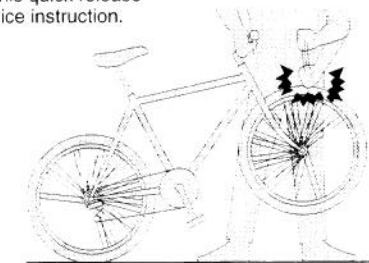

If the quick release will not adjust properly, please contact a professional dealer for advice.